



Plumbing System Sewer Inspections

For Infill Housing

The Building Standards Department issues Builder Tips as part of our customer service program. They are designed to provide an improved understanding of the Building Code and to reduce the costs associated with correcting infractions. Please contact your area building inspector for further information or call the Building Standards Department at 905.475.4848 extension 2189

ONTARIO BUILDING CODE ACT

Role of Chief building officials

- (6) It is the role of a chief building official,
- (a) to establish operational policies for the enforcement of this Act and the building code within the applicable jurisdiction;

Role of builders

- (3) It is the role of a builder,
- (a) to ensure that construction does not proceed unless any permit required under this Act has been issued by the chief building official;
 - (b) to construct the building in accordance with the permit;
 - (c) to use appropriate building techniques to achieve compliance with this Act and the building code; and
 - (d) when site conditions affect compliance with the building code, to notify the designer and an inspector or the registered code agency, as appropriate. 2002., c.9, s. 3.

ONTARIO BUILDING CODE

7.3.6.1. Tests and Inspection of Drainage or Venting Systems

- (5) A ball test shall be carried out on a sanitary building drain, sanitary building sewer, storm building drain and a storm building sewer buried underground.

7.4.10.8. Hydraulic Loads on Sanitary Building Drains or Sewers

- (1) Except as permitted by Article 7.4.10.7., the hydraulic load that is drained to a sanitary building drain or a sanitary building sewer shall conform to Table 7.4.10.6.-C.
- (2) Horizontal sanitary drainage pipe shall be designed to carry no more than 65% of its full capacity.



OBJECTIVE

The objective of this Builder Tip is to ensure adequate slope of the sewer piping will provide sufficient flow velocity to move solids in the system. Insufficient flow could cause blockages in the waste pipes, leading to a sanitary drainage backup, leading to unsanitary conditions within the dwelling.

The property owner and builder are required to construct a building in accordance with the Building Code and the approved Building Permit Documents. It is the responsibility of Building Standards Department to enforcement this requirement. This Builder Tip has been developed to establish an operational policy for the enforcement of the Building Code Act and Building Code with respect to the inspection of sewer piping of plumbing systems.

Therefore, prior to conducting the Plumbing System sewer piping inspection, the owner/builder must ensure the following information is contained on a cross-sectional and plan drawing, refer to the sample attached, and submitted to the building inspector;

- 1) The invert elevation of the sanitary sewer pipe below the underside of the footing,
- 2) The actual invert elevation of the sanitary sewer pipe at the property line,
- 3) The measured distance of the sewer piping from the building face to the location of the connection to the municipal services at the property line,
- 4) The minimum percent slope of the sanitary sewer,
- 5) The street main and sanitary sewer laterals to the property line, including the actual invert elevations at the street main and the property line, and
- 6) Show the foundation in wall section at the sanitary sewer location

Definition: *Invert Elevation:* Meaning the invert level at the base of the interior level of a pipe and is measured to a fixed datum.

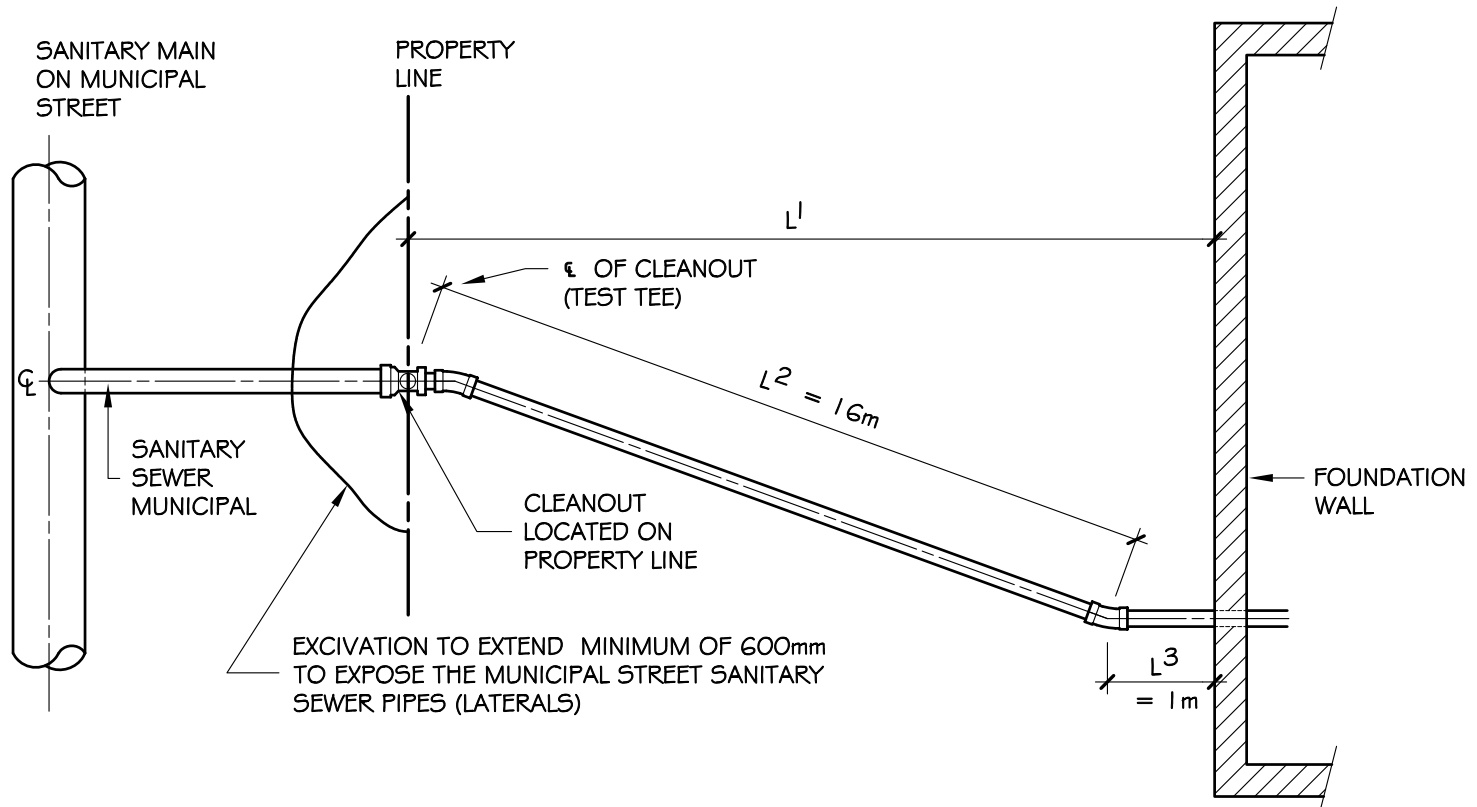

SANITARY SEWER PLAN

Building Permit Number:

Project address:

DWG. NO.

DRAWN BY: _____ Ontario Land Surveyor

DATE

SCALE

1 of 3

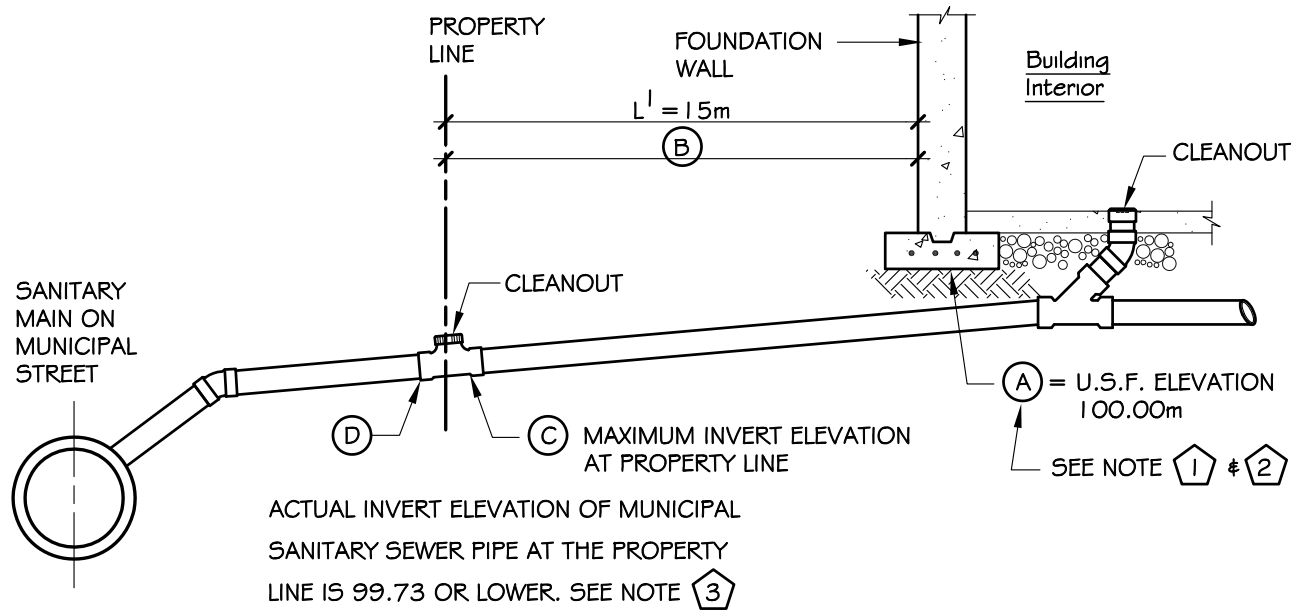

SANITARY SEWER CROSS-SECTION

CALCULATION A

(A) = U.S.F. - 0.100m (PIPE DIAMETER)

(A) = 100m - 0.10m = 99.90m

THEREFORE SANITARY SEWER INVERT AT U.S.F. IS 99.90m.

CALCULATION B

(B) = $L_2 + L_3 \times 1\% = 16\text{m} + 1\text{m} \times 1\%$

(B) = 0.17m

SEE NOTE (4)

CALCULATION C

(C) = (A) - (B)

= 99.90m - 0.17m

= 99.73m

THEREFORE MAXIMUM INVERT ELEVATION AT (C) IS 99.73m.

CALCULATION D

(D) IS = OR < (C) INVERT ELEVATION

SUMMARY

INVERT PIPE ELEVATION LOCATED UNDER THE BUILDING FOOTING =

INVERT PIPE ELEVATION AT OUTLET (DOWNSTREAM SIDE) OF THE CLEANOUT ON THE PROPERTY LINE =

TOTAL LENGTH OF PIPING FROM THE EDGE OF BUILDING FOOTING TO THE CLEANOUT ON PROPERTY LINE =

DISTANCE FROM BUILDING (TAKEN FROM LOCATION OF PIPING AT THE BUILDING FOOTING) TO THE PROPERTY LINE =

Building Permit Number:

Project address:

DWG. NO.

DRAWN BY: _____ Ontario Land Surveyor

DATE

SCALE

2 of 3

NOTES:

- 1 U.S.F. ELEVATION TAKEN FROM TOP OF WALL SURVEY.
- 2 IF THE TOP OF SEWER PIPE IS NOT DIRECTLY UNDER THE FOOTING, THE DIMENSION FROM U.S.F. TO TOP OF SEWER PIPE SHALL BE INCLUDED IN THE CALCULATION.
- 3 ACTUAL INVERT ELEVATION MUST HAVE BEEN DERIVED FROM ELEVATIONS AND MEASUREMENTS FROM O.L.S SURVEYOR.
- 4 MINIMUM SLOPE TO CONFORM WITH TABLE 7.4.10.8. OF THE ONTARIO BUILDING CODE
1% FOR MAXIMUM 180 FIXTURE UNITS
2% FOR MAXIMUM 240 FIXTURE UNITS
4% FOR MAXIMUM 300 FIXTURE UNITS

LEGEND	
U.S.F.	UNDERSIDE OF FOOTINGS
O.L.S	ONTARIO LAND SURVEYORS

Building Permit Number:

Project address:

DWG. NO.

DRAWN BY: _____ Ontario Land Surveyor

DATE

SCALE

3 of 3